



User Manual

LDP-QCW 300-12



PicoLAS GmbH
Burgstr. 2
52146 Würselen
Germany

Phone: +49 (0) 2405-64594-60
Fax: +49 (0) 2405-64594-61
E-mail: info@picolas.de
Web: www.picolas.de

Table of Contents

Product Overview	3
How to use the Manual	4
How to get started.....	5
Description of available Connectors	6
Connecting and Interfacing	7
Interface Specifications	8
Dos and Don'ts	11
Functional Description	12
Trigger Modes	13
Current Regulator	16
LED Codes	18
Power Supply.....	18
Cooling	18
Test Load	18
Overtemperature Shutdown.....	19
Absolute maximum Ratings	19
Mechanical Dimensions	20
Controlling the LDP-QCW using a PLB-21	21
Controlling the LDP-QCW via RS232.....	24
The PicoLAS Protocol.....	31



LDP-QCW 300-12

Rev. 1905

QCW Driver for High Power Laser Diodes



- Output current: 50 .. 300 A
- Compliance voltage: 2 .. 12 V
- Stackprotector® and other protective features
- High efficiency
- Compact design
- Baseplate cooled

Technical Data*

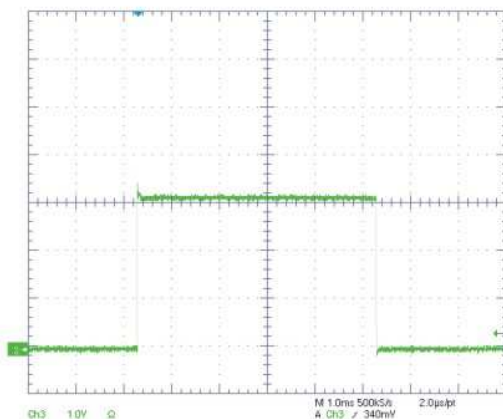

Output current	50 .. 300 A
Max. compliance voltage	12 V
Min. pulse duration	< 100 µs
Max. pulse duration	5 ms
Max. repetition rate	> 1 kHz**
Max. duty cycle	10 %**
Max. rise time	< 10 µs
Current overshoot	< 5%
Pulse trigger input	5 V TTL
Current setting input	0 .. 1.5 V external (200 A/V)
Current monitor	200 A/V
Voltage monitor	0.05 V/V
Connectivity	LDP-C BOB PLB-21 RS-232
Supply voltage	24 .. 48 V DC**
Max. power dissipation	200 W
Dimensions in mm	100 x 180 x 92
Weight	1.2 kg
Operating temperature	0 to +55 °C

Product Description

The LDP-QCW 300-12 is a compact and efficient current supply to drive qcw laser diodes. It is designed for very high currents of up to 300 A and provides power of up to 3600 W. With its compact design the LDP-QCW 300-12 has a very good power-size ratio.

For an easy use of the driver only one supply voltage is needed for the control logic and the power stage. Also the control is very convenient. In combination with the PLB-21 or via RS-232, the LDP-QCW 300-12 is capable of generating pulses on its own. No external pulse generator is required and all parameters can be comfortably adjusted.

The LDP-QCW 300-12 is suitable for a wide range of applications. That includes illumination, pumping of solid-state lasers, spot welding and others.

* Specifications measured with a fast recovery diode instead of a laser diode. Technical data is subject to change without further notice.
** See manual for details

- Stackprotector® cuts the power stage from the supply
- Innovative current control concept actively prevents laser diode from overshoots and overcurrent
- Protection against transients through adjustable current rise time
- Overtemperature shutdown
- Enable/Disable input
- Driver status output
- Protection of the laser diode against reverse currents
- Baseplate cooling, internal fans preventing hot spots

Optional Accessories: LDP-C BOB
PLB-21

How to use the Manual



Remark: The LDP-QCW described in this manual is a baseplate cooled laser diode driver. Improper cooling may cause an internal overtemperature shutdown. The two fans in one side of the unit have to prevent local thermal hot spots inside the unit. They can not compensate improper baseplate cooling. The air inside an enclosure within an OEM application is usually enough to yield enough air flow. Please do not cover any ventilation slots.

Baseplate cooling: Depending on the final application and operation regime, this unit may stay non-cooled or must be assembled onto a heat sink.

Please refer to section “Cooling” for more details about the thermal power losses during operation.

You may use a passively or an actively air/water cooled device.

Housing: All units are delivered with housing. Changes are possible; the units can be delivered without housing upon request.



Before powering on your unit, read this manual thoroughly and make sure your understood everything.



Please pay attention to all safety warnings.

If you have any doubt or suggestion, please do not hesitate to contact us!

How to get started (refer to drawings on next 2 pages)

Step	What to do	Check
1	Unpack your device and place it in front of you as shown on the next page.	
2	Connect a load (for example your laser diode) to the output.	 Make sure to use both anode and cathode connectors in parallel.
3	Connect the PLB-21 or an RS-232 cable.	A driver is required in order to use the LDP-QCW with a PC. See section “Controlling the LDP-QCW via PC” for more information.
4	Connect the input power supply. Make sure that polarity is correct. The supply voltage must be at least 24 V and about 5 V above the desired capacitor bank voltage.	 Make sure that your power supply does not have any voltage overshoots when switching on or off. Do not exceed the maximum operating voltage of 48 V.
5	Switch the power supply on.	
6	If a PLB-21 is used, its display may show a message about downloading a new driver. Confirm this with YES.	See section “Controlling the LDP-QCW using a PLB-21” for more information.
7	Set all required parameters using the PLB-21 or RS-232 interface.	See section “Controlling the LDP-QCW using a PLB-21” for more information.
8	Apply +5 V to the MasterEnable pin of the BOB connector.	See section “Interface Specifications” for more information.
9	Apply +5 V to the Enable pin of the BOB connector. This will enable the output.	See section “Interface Specifications” for more information.
10	Monitor the current pulses using an oscilloscope connected to the current monitor output.	See section “Interface Specifications” for more information.
11	Verify that the PULSER_OK signal is +5 V.	See section “Interface Specifications” for more information.

Description of available Connectors

The following drawing shows all connections which are available to the user.

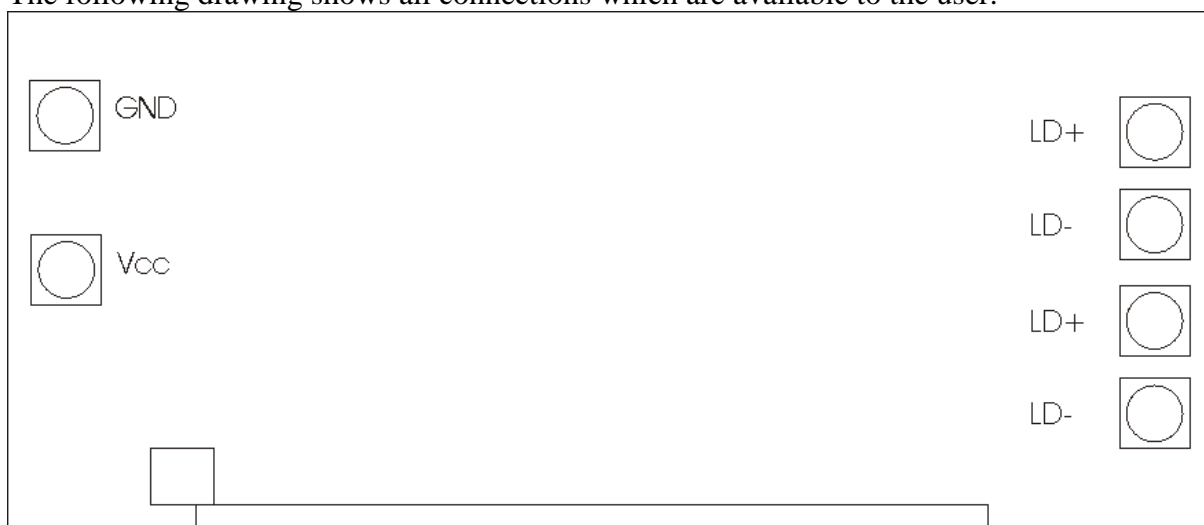

LDP-C BOB connector	See section “Interface Specifications” for detailed information (Breakout board connector).
PLB	Connector for PLB-21 (protected against polarity reversal).
Vin	Supply voltage
GND	Supply ground
LD+	Positive laser diode output (anode). Use both connectors parallel for high currents.
LD-	Negative laser diode output (cathode). Do not connect to ground! Use both connectors parallel for high currents.

For a more convenient use of the driver (e.g. in laboratory use) we recommend the optional available product accessory LDP-C BOB. Please see LDP-C BOB manual for further details.

Connecting and Interfacing



The baseplate is internally not connected to GND to avoid GND loop currents. The chassis / baseplate must be grounded by the user!



The maximum voltage between GND and chassis is 48 V. Exceeding this voltage will damage the driver and / or will cause communication errors.

This is not covered by warranty!

Strictly avoid ground loop currents through the controlling interface!

Front view

Serial sticker

indicating product type,
hardware version (HW)
and software version (SW)

Indicating LEDs

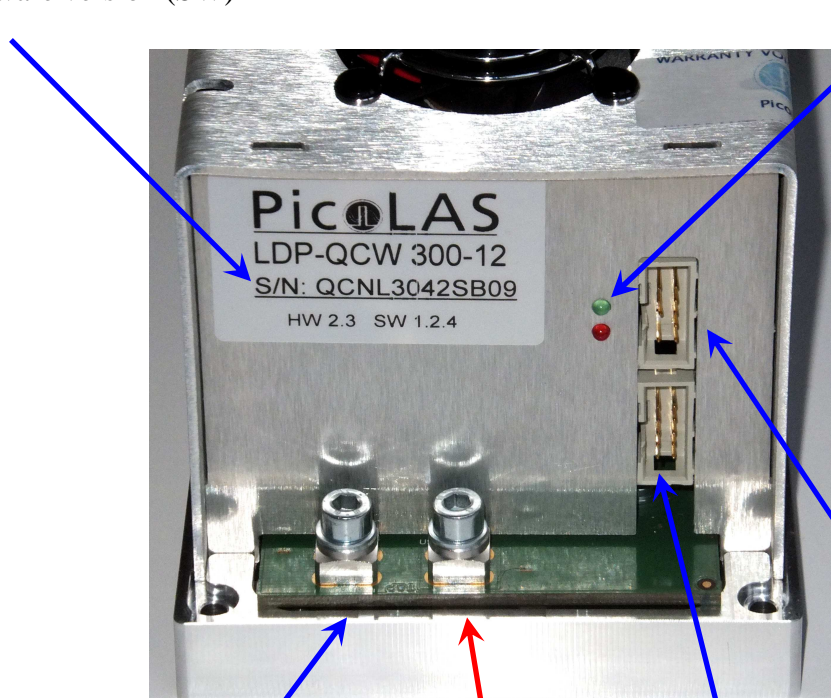

GND
(supply return)

Positive supply
voltage

Analog interface

Connect e.g.
BOB here!

Digital interface
(RS-232)

Connect PLB-21
here!

Interface Specifications

The following figure shows the input and output signals of the external analog BOB connector.

The BOB (Breakout board) is recommended for easy testing of the driver. It will be replaced in the application by your machine interface.

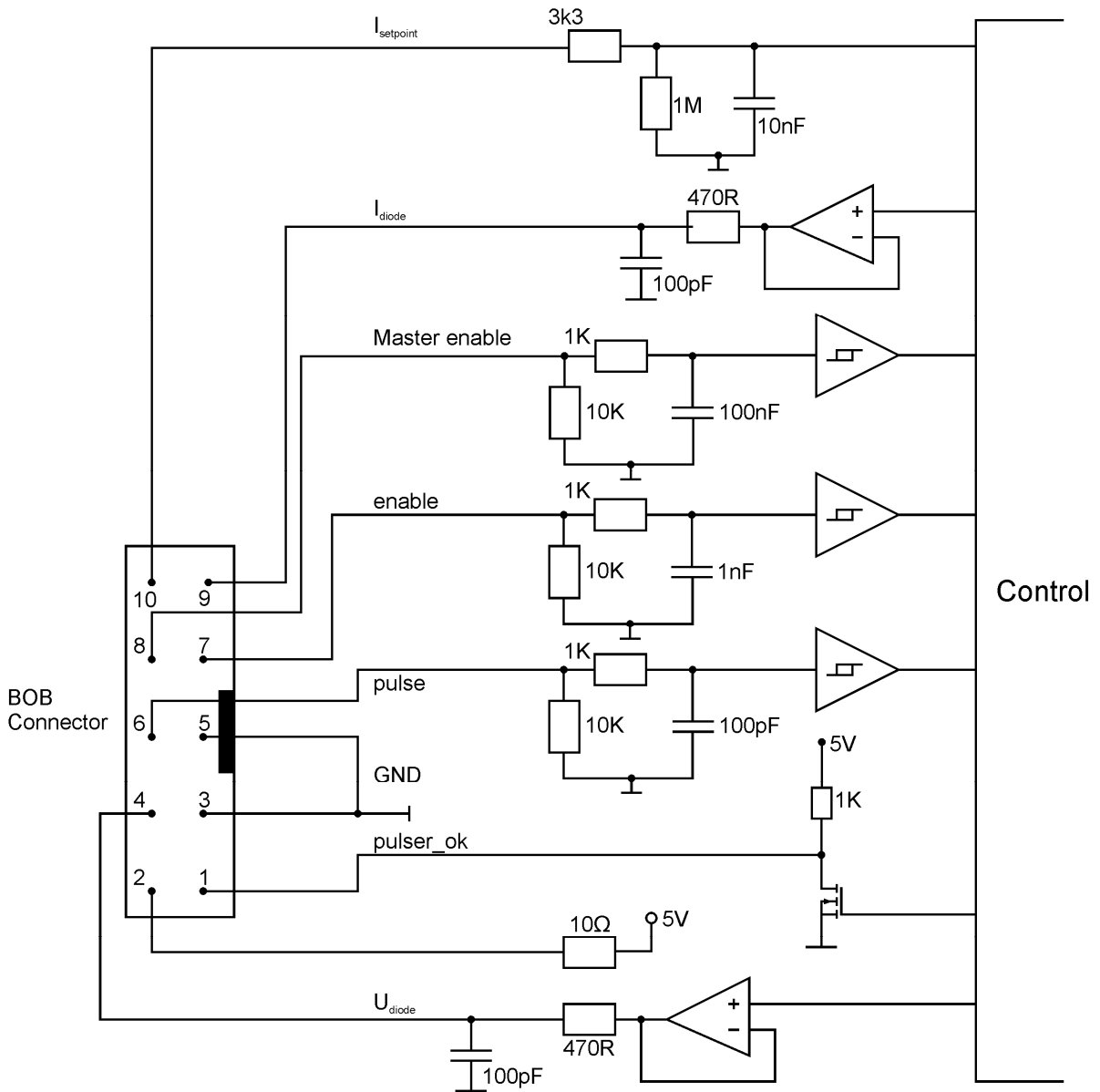

Functional description of BOB connector interface

Pin Description (numerical assorted)

Pin 1: Pulsar OK

The state of this signal indicates weather the driver is ready (5 V) or it has an error pending (0 V).

Pin 2: 5 V

This pin provides 5 Volts for external usage. Please note that the load should not exceed 10 mA. Otherwise the voltage will drop.

Pin 3: GND

This pin is connected to ground.

Pin 4: U_{diode}

This signal provides near real time measurement of the laser diodes compliance voltage. The scaling is 10 Volts per Volt measured into 1 MOhm.

Pin 5: GND

This pin is connected to ground.

Pin 6: Pulse

This signal is used in the external (trgmode = 1) and external controlled trigger mode (trgmode = 2). Connect your external trigger source to this pin. The signal amplitude should be within 3 to 6 Volts.

Pin 7: Enable

This signal is used to enable / disable the current output of the driver during operation. It must be pulled low to reset an error condition or to re-enable the driver after Master Enable was pulled low.

Pin 8: Master Enable

This signal is used as an interlock safety feature that disables the complete driver if set to 0 V during operation. In order to re-enable the driver after this emergency shutdown the enable signal must first set to 0 V.

If this feature is not required this pin can be connected to pin 2 (5 V).

Pin 9: I_{diode}

This signal provides near real time measurement of the laser diodes current flow. The scaling is 200 Amperes per Volt measured into 1 MOhm.

Pin 10: $I_{setpoint}$

This signal is used to provide an external current setpoint. The voltage at this pin is periodically sampled by the driver if it is configured to use the external setpoint current.

The PLB-21 interface is a standard RS-232 interface connection. It can be used to connect either the PLB-21 or a PC to the driver.

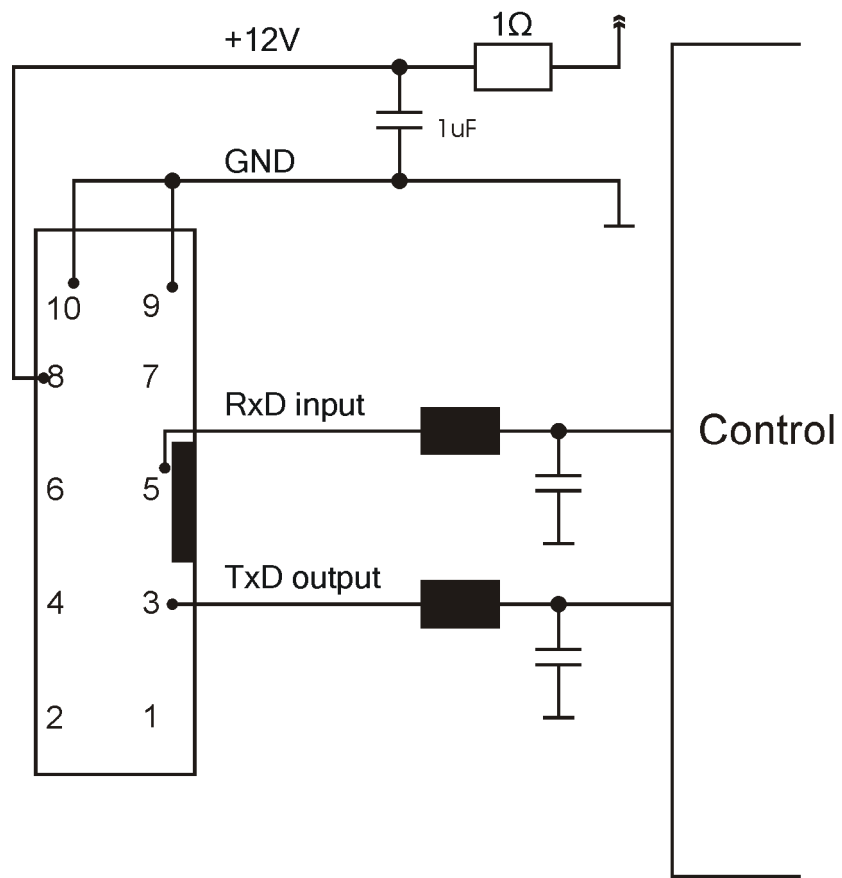

Dos and Don'ts

Never ground any output connector.

Never use any grounded probes at the output.

Do not connect your oscilloscope to the output!

This will immediately destroy the driver and the probe!

For measuring current and voltage you connect the scope to pin 9 or pin 4 of the BOB connector respectively.



Keep connecting cables between power supply and driver as well as the connection between driver and laser diode as short as possible.

Mount the driver on an appropriate heat sink!



Please be aware that there might be hot surfaces, be careful not to touch them!



Do never connect the oscilloscope to the output connectors!!!!
(Please note: above picture shows another but similar PicoLAS driver)

Functional Description

The driver uses a DC-DC converter to load a capacitor bank to a defined voltage. A PI regulator uses T_1 and a shunt to control the current flow through the laser diode.

Laser diode current and compliance voltage are pre-processed and fed to the external BOB connector.

Several security features protect the laser diode and driver from damage. D_1 protects the laser diode from reverse currents. The switch S_1 is automatically opened when an overcurrent as well as an internal failure (such as overtemperature, etc.) is detected.

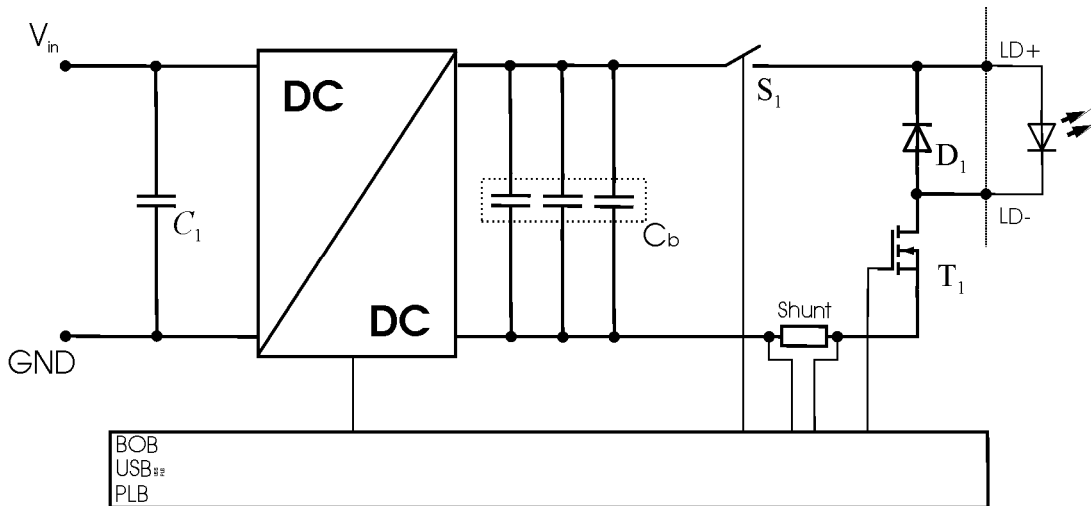

Operation principle of LDP-QCW driver

Element	Function
C1	Input buffer capacitor
Cb	Capacitor bank
S1	Security switch
D1	Laser diode protection diode
T1	Current regulation MosFET
Shunt	LD current monitor

Trigger Modes

The LDP-QCW supports four different trigger modes as explained below.

Internal (trgmode = 0)

The pulse generation is performed by an internal pulse generator. The pulse width and repetition rate is user configurable via the serial interface.

The following diagram shows an example of generated pulses. The lower graph shows the internal pulse generator and the upper two graphs the trigger pulses generated out of it.

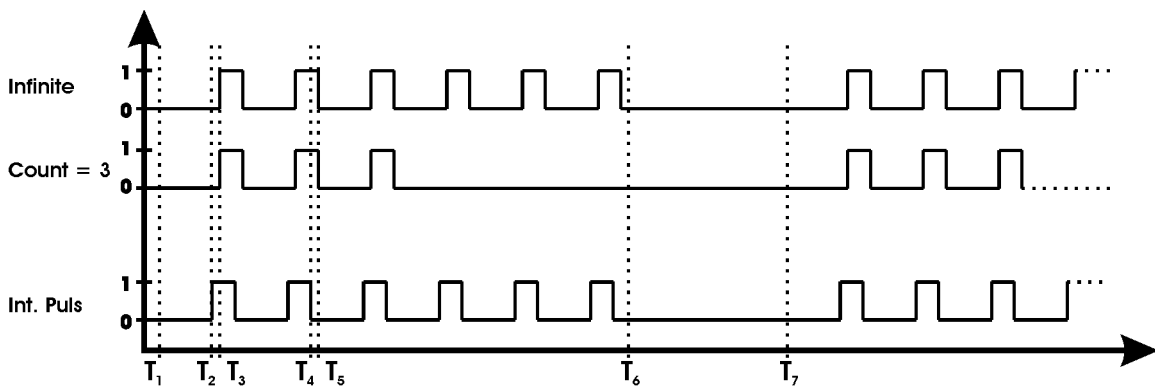

	Meaning
T_1	Enabling of the output.
T_1-T_2	The delay between output enable and the first generated pulse depends on the configured repetition rate. It nearly equals the pulse pause time.
T_2-T_3	Pulse rise time. It depends on the load inductance.
T_4-T_5	Pulse fall time. It depends on the load inductance.
T_6	Disabling of the output.
T_7	Re-enabling of the output.

External (trgmode = 1)

The pulse generation is performed by an external pulse generator connected to the pulse input on the BOB connector. The pulses can be inverted by setting the TRG_EDGE bit in the LSTAT register to “0”.

The following diagram shows an example of generated pulses. The lower graph shows the external pulse input and the upper two graphs the trigger pulses generated out of it.

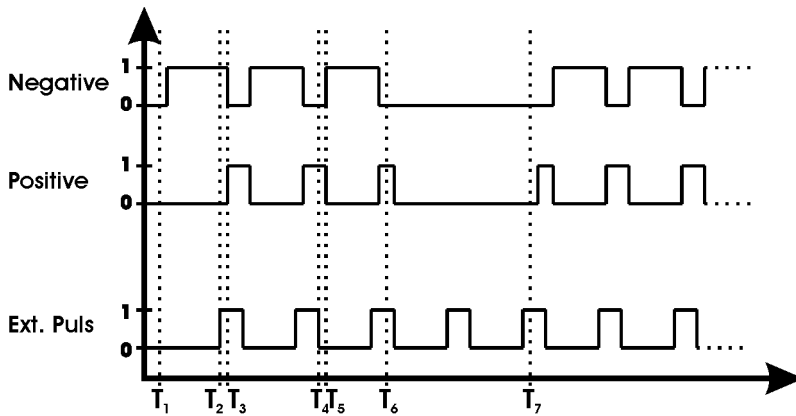

	Meaning
T ₁	Enabling of the output.
T ₂ -T ₃	Pulse rise time. It depends on the load inductance.
T ₄ -T ₅	Pulse fall time. It depends on the load inductance.
T ₆	Disabling of the output.
T ₇	Re-enabling of the output.

External controlled (trgmode = 2)

This trigger mode uses the external trigger input to control the internal pulse generator. It is used to generate a number of pulses per rising or falling edge of the external trigger input. Setting the TRG_EDGE bit in the LSTAT register to “1” uses the rising edge, setting it to “0” uses the falling edge.

The number of pulses and the repetition rate can be set via software.

The following diagram shows an example of generated pulses. The lower graph shows the external pulse input and the upper two graphs the trigger pulses generated out of it.

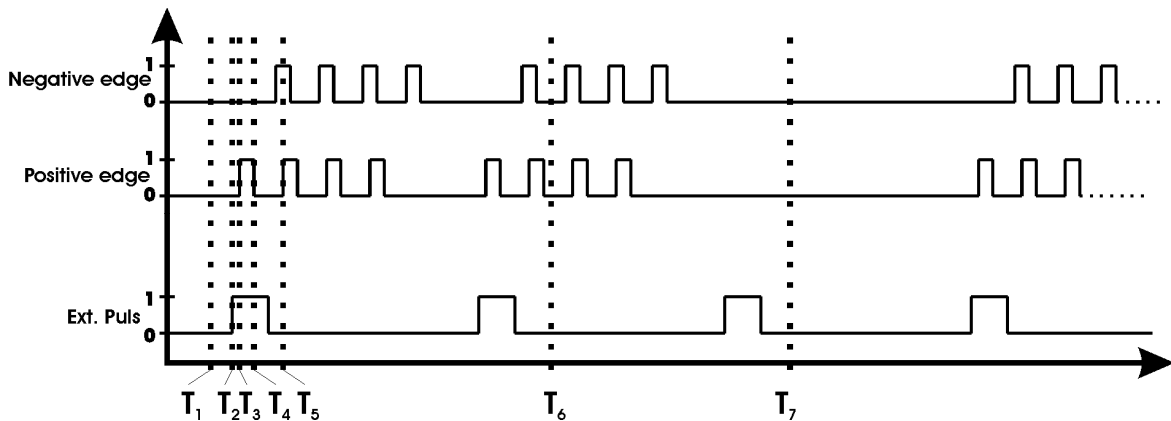

	Meaning
T1	Enabling of the output.
T2-T3	Pulse rise time. It depends on the load inductance.
T4-T5	Pulse fall time. It depends on the load inductance.
T6	Disabling of the output.
T7	Re-enabling of the output.

Software (trgmode = 3)

This trigger mode works exactly like the external controlled mode. The only difference is that the trigger is given using a software command.

Current Regulator

The LDP-QCW implements a proportional integral (PI) regulator to control the current flow through the connected load. The following diagram shows a simplified layout:

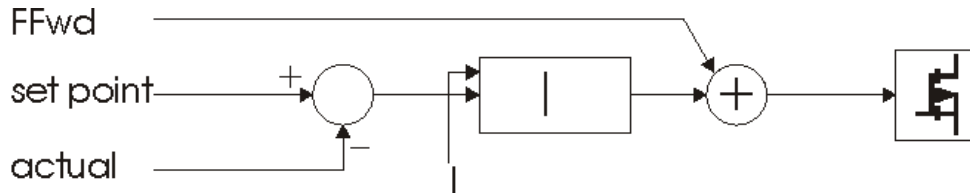

Depending on the chosen operating mode the user has the possibility to modify all relevant parameters to a specific need. This is done through the digital interface (PLB-21 or RS-232).

The proportional part of the regulator is not user accessible.

The “I” value defines the strength of the integral part of the current regulator. This value ranges from 0 to 4095. A recommended value for normal operation is 30 .. 60. If this value is too high it may lead to a current overshoot.

PicoLAS implemented an active nonlinearity compensation of the output stage. This speeds up the device, prevents excessive current overshoots and yields a better accuracy with high impedance loads.

The influence of this part of the regulator can be user defined and is called FFwd.

However, the interconnection between the voltage and the current flow on the output is calibrated during fabrication. This is used in operating mode 1. So it is not necessary to change this value at all. If needed, it can be adjusted between the values 0 to 7.5 by the customer.



Be careful if changes are performed with the FFwd value. The effect is high and may cause damage if not adjusted properly. Wrong settings are not covered by warranty.

Mode 0: manual

In this operation mode all parameters can be modified.



This mode is recommended only for experienced users as any wrong setting may lead to a current overshoot at the output.

Mode I: semi-auto

In this operation mode the feed forward value is automatically chosen in dependence of the current setpoint. This is recommended for normal operation as it guarantees no current overshoot at the output.

The P and I values can be freely chosen, but the default values are sufficient for most applications.

Overcurrent Protection

The driver is equipped with software controllable overcurrent protection. The user must configure a current value at which the driver will disable itself. This is an absolute value, hence if the setpoint current is set to a greater value than the overcurrent protection, the driver will generate only a partial pulse.

V_{Cap}

The V_{Cap} value defines the voltage of the capacitor bank (see section “Functional Description”). This value is a bit tricky to determine as it depends on the chosen pulse width, repetition rate and compliance voltage.

If his value is too low the current will drop during the pulse or not even reach the setpoint, if it is too high the output stage will heat up fast and lead to an overtemperature shutdown.

The following equation can be used to calculate the capacitor voltage in dependence of the output current, compliance voltage and pulse width:

$$V_{cap} = 5 + U_{LD} + (I_{LD}(0.011 + \frac{T_{pulse}}{0.112}))$$

where

U_{LD} = compliance voltage

I_{LD} = current setpoint

T_{pulse} = pulse width

This equation does not use the repetition rate. Hence this value must be increased if a current drop is measured during operation.

For first tests or low pulse width and repetition rate it can safely be set to maximum, but the higher this value is the greater the power losses are in the output stage.

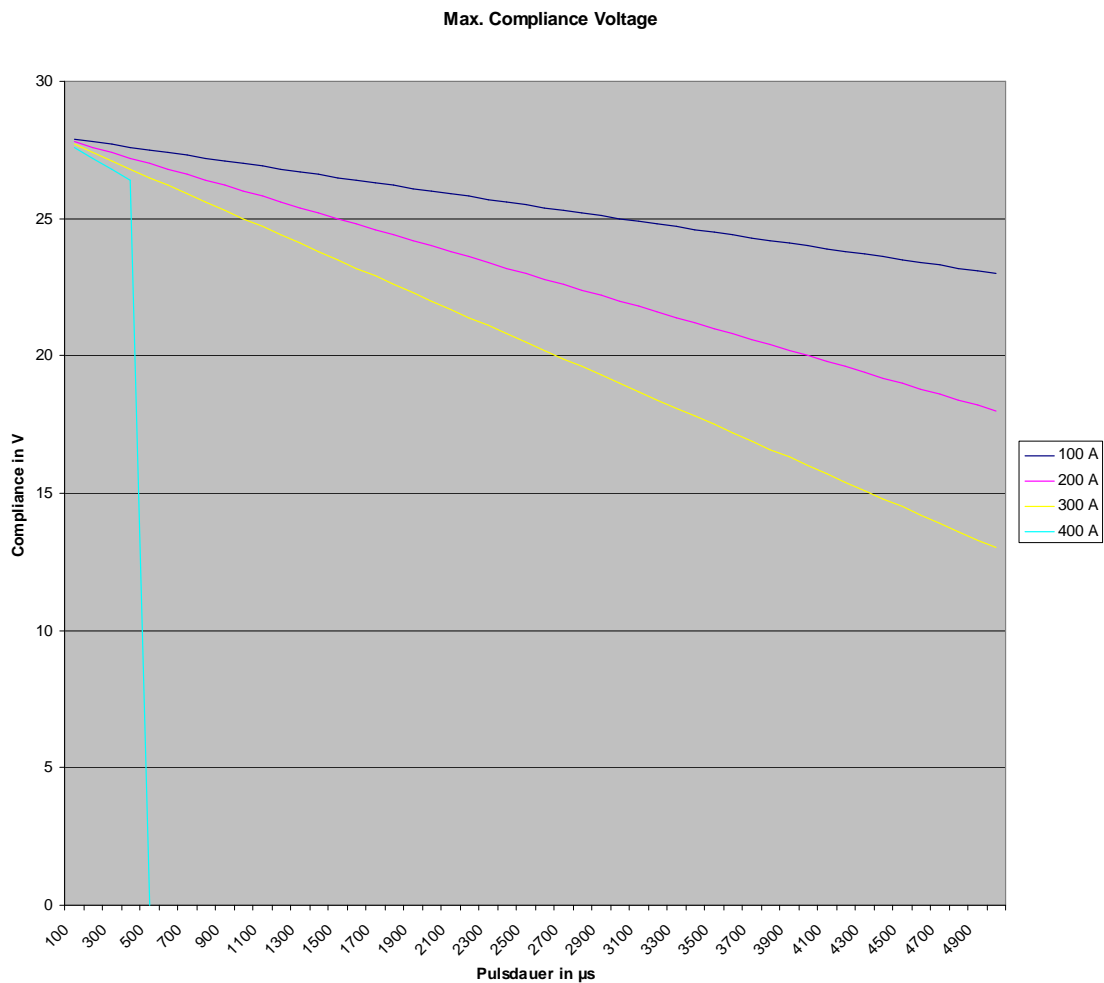

LED Codes

The LDP-QCW is equipped with a red and a green status LED.

The red LED is connected to the Pulser_ok pin of the BOB connector and will lit if the signal goes low.

The green LED has the following codes:

Permanent on:	The LDP-QCW operates normally and the current output is enabled
Blink 1x:	Master Enable is given, but Enable not
Blink 2x:	Master Enable is not given

Power Supply

To obtain a good pulsing performance with the driver, it requires an appropriate power supply unit (PSU). The PSU has to supply not only the power that is delivered to the laser diode but also the power to compensate for the losses in the driver itself.

The device is equipped with a buck-boost DC-DC converter which allows it to generate a capacitor voltage that is higher than the input voltage.

Cooling

The maximum thermal dissipation of the LDP-QCW depends on the configured pulse length, repetition rate and capacitor bank voltage. For optimal cooling the baseplate must be mounted to an appropriate heat sink or water cooling.

The LDP-QCW is equipped with two cooling fans. They are only for cooling of the internal capacitors and are not sufficient enough to cool the whole device. It is possible to control the speed of the fans via software by disabling the automatic fan speed control. If the cooling is insufficient, the device will detect an overtemperature condition and will disable itself if necessary.

Test Load

A common method to test the driver is to connect a regular silicon rectifier diode to the driver output. Here has to be paid attention to the junction capacitance of the diode. Only fast recovery diodes (or similar) have a low parasitic capacitance as laser diodes. To achieve reasonable test results the parasitic elements of the test diode and the connection must be very similar to a laser diode approach. Regular silicon rectifier diodes have a junction capacitance of several microfarads and are not a suitable test load! The use of these diodes will yield in incorrect current measurement at the pulse edges!

It is also possible to test the driver using a shortcut. This will not damage it, but result in an incorrect measurement for the rise and fall time of the current pulse.

Overtemperature Shutdown

To protect the laser diode and the driver itself, the LDP-QCW automatically disables itself if its temperature rises above the maximum allowed operating temperature. This condition is latched and the LDP-QCW will not start working until the temperature drops five degrees and the ENABLE pin is toggled. During the overtemperature shutdown, the Pulser_ok output (pin 1 of the BOB connector) is pulled low.

Absolute maximum Ratings

Output current	50 .. 300 A
Max. compliance voltage	12 V (short circuit proof)
Min. pulse duration	< 100 us
Max. pulse duration	5 ms
Max. repetition rate	> 1 kHz
Max. duty cycle	10 %
Max. rise time	< 10 μ s
Current overshoot	< 5 % (depending on regulator settings)
Pulse trigger input	5 V TTL
External current setting input	200 A/V
Current monitor	200 A/V
Connectivity	LDP-C BOB PLB-21
Supply voltage	24 .. 48 V
Max. power dissipation	TBD
Dimensions in mm	100 x 180 x 100
Weight	1.2 Kg
Operating temperature	0 to +55 °C

Mechanical Dimensions

The following dimensions are in millimetres (mm).

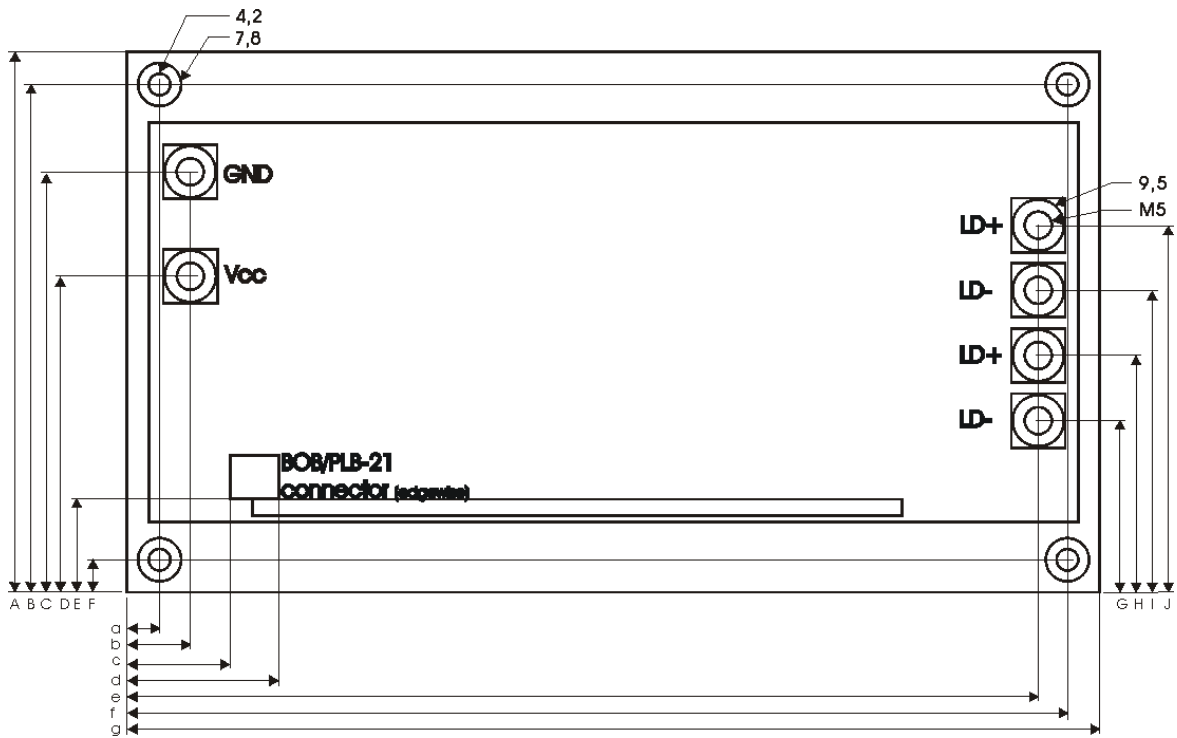

A	100		a	6
B	94		b	4.5
C	74		c	19
D	55		d	27
E	17		e	169
F	6		f	174
G	31.7		g	180
H	43.8			
I	55.9			
J	68			

Controlling the LDP-QCW using a PLB-21

To control the LDP-QCW with a PLB-21 it must be connected via the enclosed cable. When the PLB-21 is connected the first time to a LDP-QCW you are asked to download a new driver. This must be confirmed with “yes” for working the PLB-21 properly.

Menu Structure

The following diagram shows the structure of the PLB-21 menu which affects the LDP-QCW. All entries are described in detail. All other menu entries are described in the PLB-21 manual. For detailed instructions see the PLB-21 manual.

Menu root

- Main Puls
 - o MP Current
 - o FFwd
 - o I-Delay
 - o I

- Pulsgen
 - o MP Width
 - o Reprate

- Trigger
 - o Mode
 - o Edge
 - o Count

- Config
 - o Mode
 - o Cur. stp.
 - o OverCur F1
 - o Voltage

- Temperature
 - o Temp1
 - o Temp2
 - o Temp3
 - o Temp4

- Defaults
 - o Autoload
 - o Save
 - o Load

Main Puls

MP Current

This value defines the pulse current for the next pulse.

FFwd

This value represents the feed forward voltage of the current regulator. See section “Current Regulator” for more information.

I-Delay

This value represents the switching point of the integral part of the current regulator. It is defined in percent of the setpoint current. See section “Current regulator” for more information.

I

This value defines the strength of the integral part of the current regulator. The value ranges from 0 to 4095.

Pulsgen

MP Width

This value defines the pulse width of the output pulses. This is not available in every trigger mode. Please see section “Trigger Modes” for more information.

Reprate

This value defines the repetition rate of the output pulses. This is not available in every trigger mode. Please see section “Trigger Modes” for more information.

Trigger

Mode

This setting defines which trigger input / mode is used. Please see section “Trigger Modes” for more information.

Edge

This setting defines which edge / polarity is used for the trigger. This is not available in every trigger mode. Please see section “Trigger Modes” for more information.

Count

This setting defines the number of pulses generated per trigger event. This is not available in every trigger mode. Please see section “Trigger Modes” for more information.

Config

Mode

In this menu point the operation mode of the LDP-QCW can be selected. See section “Current Regulator” for more information.

Cur. stp.

The LDP-QCW can be configured to use the internal or external setpoint current. If switched to external, an appropriate voltage must be applied to the BOB connector.

OverCur

If enabled, the LDP-QCW disables automatically if the current flow reaches the given value.

Voltage

This value represents the precharge voltage of the current regulator. See section “Current Regulator” for more information.

Temperature

The LDP-QCW is equipped with several temperature sensors. In this submenu the actual and shutdown temperatures can be read and modified. All values are in °C.

Temp 1...4

This shows the actual temperatures measured by the sensors of the LDP-QCW.

Defaults

def. pwron

If enabled the LDP-QCW loads default values every time it is powered on. These values are CRC checked at power up. If this check fails the values are not loaded and an error message is displayed.

Save defaults

When the Jogdail is turned or the ENTER key is pressed all current values are saved.

Load defaults

When the Jogdail is turned or the ENTER key is pressed all current values are overwritten by the saved ones. If the output was enabled at this time it becomes disabled.

If an Error Occurs

If an error occurs during operation the pulse output is switched off, the “pulser_ok_ext” signal on the BOB connector is pulled low and a message is displayed on the PLB-21. If no other action is described on the display, a toggle of the ENABLE pin resets the error condition.

Controlling the LDP-QCW via RS-232

Introduction

The RS-232 interface allows communications over a serial text interface as well as using the PicoLAS protocol. While the text interface is designed for communication with a terminal program, the PicoLAS protocol is designed as a system interact protocol.

The switching between the two protocols occurs automatically as soon as the LDP-QCW receives a certain sequence. The corresponding commands are:

- **PING** for the PicoLAS protocol
- **“init”** followed by <Enter> for the text interface

The connection settings are:

Baud rate	115200
Data bits	8
Stop bits	1
Parity	even

The Serial Text Interface

The following section describes the structure and commands of the text interface.

Structure

Every command that is sent to the LDP-QCW must be completed with a CR (Enter). It consists of a command word followed by one or more parameters. If the command was successfully executed a "00" is sent, otherwise a "01". If there is an error pending, the response will be "10", otherwise "11". If the command requires an answer parameter, this parameter is sent before the confirmation is given.

Example:

The user would like to read out the actual setpoint current:

User input: gcurrent<Enter>

Output of the LDP-QCW: 250<CR><LF>

00<CR><LF>

Example 2:

The user would like to set a new setpoint current:

User input: scurrent 270<Enter>

Output of the LDP-QCW: 270<CR><LF>

00<CR><LF>

Input is done in ASCII code and is case sensitive. Every terminal can be used that supports this standard.

Commands for the LDP-QCW

The following table contains a command reference for the LDP-QCW.

Command	Parameter	Description
ghwver	-	returns the hardware version number
gswver	-	returns the software version number
gserial	-	returns the serial number
gname	-	returns the device name
ps	-	prints out all settings
loaddef	-	loads default values
savedef	-	saves all settings as default values
enautodef	-	enables the automatic loading of default settings on power on
disautodef	-	disables the automatic loading of default settings on power on
gerrtxt	-	returns the error register in text form
gerr	-	returns the error register as a 32 bit number
glstat	-	returns the laser status register
slstat	32 bit number	sets the laser status register to the given value
gtrgedge	-	returns “0” for negative edge or “1” for positive edge
strgedge	0 or 1	sets the trigger edge for external trigger “0” = negative “1” = positive
gmode	-	returns the current regulator mode Mode 0: manual Mode 1: semi-automatic See section “Current Regulator” for more information
smode	0 ... 1	sets the current regulator mode to the given value Mode 0: manual Mode 1: semi-automatic See section “Current Regulator” for more information

Command	Parameter	Description
gisoll	-	returns the actual setpoint current of the pulse in [A]
gisollmin	-	returns the minimum setpoint current of the main pulse
gisollmax	-	returns the maximum setpoint current of the pulse
sisoll	current in [A]	sets the internal setpoint current of the pulse to the given value. This value must be within the minimum/maximum borders (see above). The return value is the new setpoint.
gtemp	-	returns the actual device temperature in °C. This is the maximum of the single temperature sensors
gtemp1	-	returns the value of temp. sensor number 1 in [°C]
gtemp2	-	returns the value of temp. sensor number 2 in [°C]
gtemp3	-	returns the value of temp. sensor number 3 in [°C]
gtemp4	-	returns the value of temp. sensor number 4 in [°C]
gtemp5	-	returns the value of temp. sensor number 5 in [°C]
gtemp6	-	returns the value of temp. sensor number 6 in [°C]
gtempphys	-	returns the temperature at witch the device switches back on after an overtemperature shutdown in [°C]
gtempwarn	-	returns the temperature at witch the TEMP_WARN bit in the ERROR register is set
gtempoff	-	returns the overtemperature shutdown value in [°C]
gwidth	-	returns the actual pulse width for the main pulse in [us]
gwidthmin	-	returns the minimum possible pulse width for the pulse in [us]
gwidthmax	-	returns the maximum possible pulse for the pulse in [us]
swidth	width in [us]	sets the pulse width for the pulse. Please note that any change in this register affects the maximum possible repetition rate. The return value is the new pulse width.
greprate	-	returns the actual repetition rate in [Hz]
grepratemin		returns the minimal possible repetition rate in [Hz]
grepratemax		returns the maximal possible repetition rate in [Hz]
sreprate	reprate in [Hz]	sets the pulse repetition rate to the given value. The return value is the new repetition rate.
gvcap	-	returns the actual pre charge voltage of the internal capacitor bank in [V].

Command	Parameter	Description
gvcapmin	-	returns the minimum pre charge voltage of the internal capacitor bank in [V]
gvcapmax	-	returns the maximum pre charge voltage of the internal capacitor bank in [V]
svcap	voltage in [V]	sets the pre charge voltage of the internal capacitor bank to the given value in [V]. One position after decimal point is used (e.g. 12.5)
gidelay	-	returns the delay value to witch the output current of the pulse must rise before the integral part of the current regulator is switched on. This value is measured in percent of the setpoint current.
sidelay	delay in %	sets the delay value to witch the output current of the pulse must rise before the integral part of the current regulator is switched on to the given value. This value is measured in percent of the setpoint current.
gidelaymin	-	returns the minimum i-delay value
gidelaymax	-	returns the maximum i-delay value
gi	-	returns the actual strength of the integral part of the current regulator for the pulse
si	value	sets the strength of the integral part of the current regulator for the pulse to the given value
gimin	-	returns the minimum strength of the integral part of the current regulator
gimax	-	returns the maximum strength of the integral part of the current regulator
gffwd	-	returns the actual voltage of the feed-forward part of the current regulator for the main pulse in [V]. See section “Current Regulator” for more information.
sffwd	voltage in [V]	sets the feed-forward voltage for the pulse to the given value. Two positions after decimal point are used (e.g. 3.45). It must be within the borders of gffwdmin / gffwdmax.

Command	Parameter	Description
gffwdmin	-	returns the minimum possible value of the feed-forward voltage in [V]
gffwdmax	-	returns the maximum possible value of the feed-forward voltage in [V]
gocur	-	returns the actual overcurrent shutdown value in [A]. The output will be disabled when the output current reaches this value. Please note that this function must be enabled to use it.
gocurmin	-	returns the minimum possible overcurrent shutdown value in [A]
gocurmax	-	returns the maximum possible overcurrent shutdown value in [A]
socur	current in [A]	sets the overcurrent shutdown value to the given value in [A]. The output will be disabled when the output current reaches this value. Please note that this function must be enabled to use it.
enocur	-	enables the overcurrent protection
disocur	-	disables the overcurrent protection
gadcudiode	-	returns the actual measured pulse current in [A]
gadcidiode	-	returns the actual measured pulse voltage in [V]
gadvcap	-	returns the actual measured capacitor bank voltage in [V]
gadcuin	-	returns the actual measured input voltage in [V]
gadcisollhp	-	returns the actual measured analogue setpoint for the main pulse
gadcnm	-	returns the number of samples that was taken during the last generated pulse
gadcpulsudiode	<sample num>	returns the pulse current during the given sample number in [A]
gadcpulsidiode	<sample num>	returns the pulse voltage during the given sample number in [A]
gadcpulsvcap	<sample num>	returns the capacitor voltage during the given sample number in [A]
gadcpulshp	<sample num>	returns the strength of the integration part of the regulator for the pre pulse during the given sample number
gadcpulsivp	<sample num>	returns the strength of the integration part of the regulator for the main pulse during the given sample number
gcount	-	returns the actual configured number of pulses to be generated

Command	Parameter	Description
gcountmin	-	returns the minimum possible number of pulses to be generated
gcountmax	-	returns the maximum possible number of pulses to be generated
scount	number	sets the number of pulses to be generated
execpuls	--	generates a software trigger
strgmode	0 ... 3	sets the pulse generator trigger mode to the given value Mode 0: internal Mode 1: external Mode 3: external controlled Mode 4: software controlled See section “Trigger Modes” for more information
gtrgmode	--	returns the actual used trigger mode
isoll_ext	--	switches the setpoint to analog
isoll_int	--	switches the setpoint to digital
enable_int	--	switches to internal enable control (does not work yet)
enable_ext	--	switches to external enable control
sfanmode	0 or 1	sets the cooling fan to manual (0) or automatic mode (1)
sfan	speed in %	sets the speed of the cooling fan to the given value in %
gfanmin	--	returns the minimum fan speed in %
gfanmax	--	returns the maximum fan speed in %
gfan	--	returns the actual fan speed in %
gfanspd1	--	returns the actual speed of fan 1 in rpm (does not work yet)
gfanspd2	--	returns the actual speed of fan 2 in rpm (does not work yet)

If an Error occurs

If an error occurs during operation the pulse output is switched off and the return value of a command is no longer “00” or “01” but “10” or “11”. **Errors have to be acknowledged with a toggle of the ENABLE signal. Otherwise switching on again of the pulse output is not possible.**

To retrieve the error use the **gerror** command for the content of the ERROR register or the **gerrtxt** command for a human readable form.

The PicoLAS Protocol

The following section describes the structure and possible commands of the PicoLAS protocol.

Structure

Each transmission consists of 12 bytes – called a frame as follows – which must be sent consecutively. Otherwise the system times out and the transmission must start again from the beginning.

A frame has a fixed structure. The first two bytes describe the command, the following eight bytes the parameters, followed by one reserved byte and one checksum byte. The checksum is calculated out of the first 11 bytes which are linked by a bitwise XOR.

Thus a frame has the following structure:

Byte	Meaning
1	Bit 8-15 of the command
2	Bit 0-7 of the command
3	Bit 56-63 of the parameter
4	Bit 48-55 of the parameter
5	Bit 40-47 of the parameter
6	Bit 32-39 of the parameter
7	Bit 24-31 of the parameter
8	Bit 16-23 of the parameter
9	Bit 8-15 of the parameter
10	Bit 0-7 of the parameter
11	Reserved, always 0x00
12	Checksum

A properly received frame must be acknowledged by the recipient with an answer, which is also a frame. If the acknowledgement does not occur the command has not been processed and the sending procedure should be repeated.

If the recipient recognizes the command as valid but not the parameters, then it will answer with an ILGLPARAM (0xFF12) as command.

In case that the recipient receives an invalid command it will answer with UNCOM (0xFF13).

If a faulty checksum is recognized then the answer is RXERROR (0xFF10). If this error occurs often the connection should be checked.

Using the REPEAT (0xFF11) command the recipient can instruct the sender to send the most recent frame again.

General Commands

The following list contains an overview of the general commands which are supported by every product from PicoLAS which makes use of this protocol. The explanation of the individual commands is given further below.

Command Name	Sent Frame		Answer Frame	
	Command	Parameter	Command	Parameter
PING	0xFE01	0	0xFF01	0
IDENT	0xFE02	0	0xFF02	ID
GETHARDVER	0xFE06	0	0xFF06	Version
GETSOFTVER	0xFE07	0	0xFF07	Version
GETSERIAL	0xFE08	0 ... 255	0xFF08	Refer to description
GETIDSTRING	0xFE09	0 ... 255	0xFF09	Refer to description

PING

This command is used to determine the presence of a connected device and to initialize the interface. It has no effect on the condition of the recipient. The command parameter is always zero, the answer parameter too.

IDENT

It is used to determine the device ID of an attached recipient. It has no effect on the condition of the recipient. The parameter is always 0. The answer contains the ID.

GETHARDVER

This command instructs the recipient to send back the version number of the hardware being used. The parameter is always zero. The answer contains the hardware version of the recipient. The format of the answer is: 0x000000<major><minor><revision>. In other words: one byte for each of the three elements of the version number.

As example, version 1.2.3 has the parameter 0x000000010203.

GETSOFTVER

Instructs the recipient to send back the version number of the software being used. The parameter is always 0.

The answer contains the software version of the recipient. The format of the answer is: 0x000000<major><minor><revision>. In other words: one byte for each of the three elements of the version number.

As example, version 2.3.4 has the parameter 0x000000020304.

GETSERIAL

Instructs the recipient to send back its serial number. If 0 is sent as parameter, the answer contains the number of (ASCII) digits of the serial number. Otherwise the respective position of the serial number is sent in ASCII format.

GETIDSTRING

Instructs the recipient to send back the name of the device. If 0 is sent as parameter, the answer contains the number of digits of the string. Otherwise the respective position of the serial number is sent in ASCII format.

In addition to these commands there are some answers, which can be given to every command:

Answer	Answer Frame	
	Command	Parameter
RXERROR	0xFF10	0
REPEAT	0xFF11	0
ILGLPARAM	0xFF12	0
UNCOM	0xFF13	0

RXERROR

If a frame is repeated four times and still broken this answer will be send.

REPEAT

The last frame was received in a broken state. The transmission must be repeated. This can be up to four times before a RXERROR will be send.

ILGLPARAM

The parameter of the last frame had an incorrect value.

UNCOM

The command of the last frame is unknown by the device.

Commands for the LDP-QCW

The following table contains a list of the commands which the LDP-QCW supports in addition to the generally applicable commands. An explanation of each individual command follows afterwards.

Command	Sent Frame		Received Frame	
	Command	Parameter	Command	Parameter
GETTEMP	0x1	0	0x100	temperature in 1/10 °C
GETTEMP1	0x2	0	0x100	temperature in 1/10 °C
GETTEMP2	0x3	0	0x100	temperature in 1/10 °C
GETTEMP3	0x4	0	0x100	temperature in 1/10 °C
GETTEMP4	0x5	0	0x100	temperature in 1/10 °C
GETTEMPPOFF	0x6	0	0x100	temperature in 1/10 °C
GETTEMPHYS	0x8	0	0x100	temperature in 1/10 °C
GETLSTAT	0x10	0	0x110	32 bit number
SETLSTAT	0x11	32 bit number	0x110	32 bit number
GETERROR	0x20	0	0x120	32 bit number
GETWIDTH	0x35	0	0x130	width in [us]
GETWIDTHMIN	0x36	0	0x130	minimum width in [us]
GETWIDTHMAX	0x37	0	0x130	maximum width in [us]
SETWIDTH	0x38	width in [us]	0x130	width in [us]
GETREPRATE	0x39	0	0x130	reprate in [Hz]
GETREPRATEMIN	0x3A	0	0x130	reprate in [Hz]
GETREPRATEMAX	0x3B	0	0x130	reprate in [Hz]
SREPRATE	0x3C	reprate in [Hz]	0x130	reprate in [Hz]
GETCOUNT	0x3D	0	0x130	number of pulses
SETCOUNT	0x3E	number of pulses	0x130	number of pulses
EXECULSE	0x3F	0	0x130	executes a software trigger
GETFFWD	0x42	0	0x140	voltage in 1/100 V
SETFFWD	0x43	voltage in 1/100 V	0x140	voltage in 1/100 V
GETFFWDMIN	0x44	0	0x140	minimum voltage in 1/100 V
GETFFWDMAX	0x45	0	0x140	maximum voltage in 1/100 V
GETCAP	0x50	0	0x150	voltage in 1/10 V
GETCAPMIN	0x51	0	0x150	minimum voltage in 1/10 V

Command	Sent Frame		Received Frame	
	Command	Parameter	Command	Parameter
GETCAPMAX	0x52	0	0x150	maximum voltage in 1/10 V
SETCAP	0x53	voltage in 1/10 V	0x150	voltage in 1/10 V
GETI	0x62	0	0x160	strength of I
SETI	0x63	strength of I	0x160	strength of I
GETIMIN	0x64	0	0x160	minimum I value
GETIMAX	0x65	0	0x160	maximum I value
GETCUR	0x74	0	0x170	current in [A]
GETCURMIN	0x75	0	0x170	minimum current in [A]
GETCURMAX	0x76	0	0x170	maximum current in [A]
SETCUR	0x77	current in [A]	0x170	current in [A]
GETOCUR	0x80	0	0x180	current in [A]
GETOCURMIN	0x81	0	0x180	minimum current in [A]
GETOCURMAX	0x82	0	0x180	maximum current in [A]
SETOCUT	0x83	current in [A]	0x180	current in [A]
GETIDELAY	0x92	0	0x190	delay in 1/10 %
SETIDELAY	0x93	delay in 1/10 %	0x190	delay in 1/10 %
GETIDELAYMIN	0x94	0	0x190	minimum delay in 1/10 %
GETIDELAYMAX	0x95	0	0x190	maximum delay in 1/10 %
LOADDEFAULTS	0xB0	0	0x1B0	0 (see below)
SAVEDEFAULTS	0xB1	0	0x1B0	0 (see below)
GETADCUDIODE	0xC0	0	0x1C0	output voltage in 1/10 V
GETADCIDIODE	0xC1	0	0x1C0	output current in [A]
GETADCVCAP	0xC2	0	0x1C0	capacitor voltage in 1/10 V
GETADC5V	0xC3	0	0x1C0	internal 5 V in 1/10 V

Command	Sent Frame		Received Frame	
	Command	Parameter	Command	Parameter
GETADCUIN	0xC5	0	0x1C0	input voltage in 1/10 V
GETADCISOLL	0xC6	0	0x1C0	external setpoint current for pre pulse in [A]
GETADCPULSSAMPLES	0xC7	0	0x1C0	see below
GETADCPULSIDIODE	0xC8	see below	0x1C0	output current in [A]
GETADCPULSUDIODE	0xC9	see below	0x1C0	output voltage in 1/10 V
GETADCPULSVCAP	0xCA	see below	0x1C0	capacitor voltage in 1/10 V
GETADCPULSIVP	0xCB	see below	0x1C0	see below
GETADCPULSIHP	0xCC	see below	0x1C0	see below
GETFAN	0xD0	0	0x1D0	fan speed in %
GETFANMIN	0xD1	0	0x1D0	minimum fan speed in %
GETFANMAX	0xD2	0	0x1D0	maximum fan speed in %
SETFAN	0xD3	fan speed in %	0x1D0	fan speed in %
GETFANSPEED1	0xD4	0	0x1D0	fan speed in rpm
GETFANSPEED2	0xD5	0	0x1D0	fan speed in rpm

Description of the individual Commands

GETTEMP

Returns the maximum of the GETTEMP1 ... GETTEMP4 commands. The value is encoded as a signed integer (16 bit), measured in steps of 0.1 °C.

GETTEMP1...4

Returns the measured value of the according temperature sensor. The value is encoded as a signed integer (16 bit), measured in steps of 0.1 °C.

GETTEMPOFF

Returns the temperature border at which the device shuts down automatically. The value is encoded as a signed integer (16 bit), measured in steps of 0.1 °C.

GETTEMPHYS

Returns the temperature to which the device must cool down until it can be switched on again. The value is encoded as a signed integer (16 bit), measured in steps of 0.1 °C.

GETLSTAT

Returns the content of the laser status register (32 bit). For a detailed description of the single bits see section "Description of the LSTAT Register".

SETLSTAT

Sets the laser status register to the given value. The return value contains the acquired register content. For a detailed description of the single bits see section "Description of the LSTAT Register".

GETERROR

Returns the content of the error register (32 bit). For a detailed description of the single bits see section "Description of the ERROR Register".

GETWIDTH

Returns the actual pulse width of the pulse. The value is measured in [us].

GETWIDTHMIN

Returns the minimum possible pulse width of the pulse. The value is measured in [us].

GETWIDTHMAX

Returns the maximum possible pulse width of the pulse. This value depends of the current repetition rate. Hence, any change in the repetition rate changes this value too. It is measured in [us].

SETWIDTH

Sets the pulse width of the pulse generator to the given value. It must be within the borders defined by GETWIDTHHPMIN and GETWIDTHHPMAX. The value is measured in [us].

GETREPRATE

Returns the actual pulse repetition rate of the internal pulse generator. The value is measured in [Hz].

GETREPRATEMIN

Returns the minimum possible pulse repetition rate of the internal pulse generator. The value is measured in [Hz].

GETREPRATEMAX

Returns the maximum possible pulse repetition rate of the internal pulse generator. The value is measured in [Hz].

SETWIDTH

Sets the pulse repetition rate of the pulse generator to the given value. It must be within the borders defined by GETREPRATEMIN and GETREPRATEMAX. The value is measured in [Hz].

GETCOUNT

Returns the number of pulses that will be generated with a given trigger. This is only used in trigger modes 2 and 3.

SETCOUNT

Sets the number of pulses that will be generated with a given trigger to the given value. This is only used in trigger modes 2 and 3. The value must be within 1 and 1000000.

GETFFWD

Returns the actual feed forward voltage used by the pulse current regulator. See Section “Current Regulator” for more information. It is measured in steps of 0.01 [V]

SETFFWD

Sets the feed forward voltage used by the pulse current regulator to the given value. It must be within the borders defined by GETFFWDMIN and GETFFWDMAX. See section “Current Regulator” for more information. The value is measured in steps of 0.01 [V]

GETFFWDMIN

Returns the minimal feed forward voltage used by the current regulator. It is measured in steps of 0.01 [V]

GETFFWDMAX

Returns the maximal feed forward voltage used by the current regulator. It is measured in steps of 0.01 [V]

GETCAP

Returns the actual pre charge voltage of the capacitor bank. See section “Current Regulator” for more information. It is measured in steps of 0.1 [V]

GETCAPMIN

Returns the minimal pre charge voltage of the capacitor bank. It is measured in steps of 0.1 [V]

GETCAPMAX

Returns the maximal pre charge voltage of the capacitor bank. It is measured in steps of 0.1 [V]

SETCAP

Sets the pre charge voltage of the capacitor bank to the given value. It must be within the borders defined by GETCAPMIN and GETCAPMAX. See section “Current Regulator” for more information. The value is measured in steps of 0.1 [V]

GETI

Returns the actual strength of the integral part of the pulse current regulator. See section “Current Regulator” for more information.

SETI

Sets the strength of the proportional part of the main current regulator to the given value. It must be within the borders defined by GETIMIN and GETIMAX. See section “Current Regulator” for more information.

GETIMIN

Returns the minimal strength of the integral part of the current regulator.

GETIMAX

Returns the maximal strength of the integral part of the current regulator.

GETCUR

Returns the actual setpoint current of the main pulse current regulator. See section “Current Regulator” for more information. The value is measured in [A].

GETCURMIN

Returns the minimal setpoint current of the pulse current regulator. It is measured in [A].

GETCURMAX

Returns the maximal setpoint current of the pulse current regulator. It is measured in [A].

SETCUR

Sets the setpoint current of the main pulse current regulator to the given value. It must be within the borders defined by GETCURMIN and GETCURMAX. See section “Current Regulator” for more information. The value is measured in [A].

GETOCUR

Returns the actual overcurrent protection border. If the output current reaches this value, the output became disabled. The value is measured in [A].

Please note that this protective feature needs to be enabled.

GETOCURMIN

Returns the minimal possible value useable for overcurrent protection. It is measured in [A].

GETOCURMAX

Returns the maximal possible value useable for overcurrent protection. It is measured in [A].

SETOCUR

Sets the overcurrent protection border to the given value. It must be within the borders defined by GETOCURMIN and GETOCURMAX. The value is measured in [A].

GETIDELAY

Returns the switching on threshold of the integral part of the pulse current regulator. If the output current reaches this value, the integral part will be enabled. The value is measured in 0.1[%] of the setpoint. See section “Current Regulator” for more information.

SETIDELAY

Sets the switching on threshold of the integral part of the main current regulator to the given value. If the output current reaches this value, the integral part will be enabled. The value is measured in 0.1[%] of the setpoint. See section “Current Regulator” for more information.

GETIDELAYMIN

Returns the minimal possible value useable as switching on threshold. It is measured in 0.1[%].

GETIDELAYMAX

Returns the maximal possible value useable as switching on threshold. It is measured in 0.1[%].

LOADDEFAULTS

This command replaces all internal parameters with their default values. If the output is enabled during the execution of this command, the L_ON bit of the LSTAT register will be cleared and the output disabled. This command will fail if the CRC_DEFAULT_FAIL bit in the ERROR register is set, indicating an error within the data.

If the DEF_PWRON bit in the LSTAT register is set, the device automatically loads these values during power up.

SAVEDEFAULTS

This command saves all internal parameters into an EEPROM for later usage. Use command LOADDEFAULTS to restore them.

GETADCUDIODE

Returns the current output voltage of the device. The value is measured in 0.1 [V].

GETADCIDIODE

Returns the current output current of the device. The value is measured in [A].

GETADCVCAP

Returns the voltage of the capacitor bank. The value is measured in 0.1 [V].

GETADCISOLL

Returns the external setpoint current. If the ISOLL_EXT bit in the LSTAT register is set, this value is used instead of the internal one. It is measured in [A].

GETADCPULSSAMPLES

Returns the number of samples taken by the LDP-QCW during the last pulse. Please see section “Pulse Measurement” for more information.

GETADCPULSIDIODE

This command takes the number of the desired sample and returns the appropriate measurement value. It is measured in [A]. If an invalid sample number is given, ILGLPARAM will be send.

GETADCPULSUDIODE

This command takes the number of the desired sample and returns the appropriate measurement value. It is measured in 0.1[V]. If an invalid sample number is given, ILGLPARAM will be send.

GETADCPULSVCAP

This command takes the number of the desired sample and returns the appropriate measurement value. It is measured in 0.1 [V]. If an invalid sample number is given, ILGLPARAM will be send.

GETADCPULSI

This command takes the number of the desired sample and returns the appropriate measurement value. If an invalid sample number is given, ILGLPARAM will be send.

GETFAN

This command returns the speed of the cooling fans in %.

GETFANMIN

This command returns the minimum speed of the cooling fans in %.

GETFANMAX

This command returns the maximum speed of the cooling fans in %.

SETFAN

This command returns the speed of the cooling fans to the given value in %. I must be within the borders defined by GETFANMIN and GETFANMAX.

GETFANSPEED1

This command returns the speed of the cooling fan 1 in rounds pre minute (rpm). Please note that this command does not work yet.

GETFANSPEED2

This command returns the speed of the cooling fan 2 in rounds pre minute (rpm). Please note that this command does not work yet.

Description of the LSTAT Register

The following list contains a description of the individual LSTAT bits. These can be read with the GETLSTAT and written with SETLSTAT command.

Bit	Name	Read/Write	Meaning
0	ENABLE_OK	ro/rw	Indicates the state of the ENABLE pin of the BOB connector.
1	MASTER_ENABLE_1	ro	Indicates the state of the Interlock_1 pin of the BOB connector.
2	MASTER_ENABLE_2	ro	Indicates the state of the Interlock_2 pin of the BOB connector.
3	PULSER_OK	ro	When the bit is read "0" an error has occurred.
4	DEF_PWRON	r/w	When "1" the device loads its default values on power on.
5	INIT_COMPLETE	ro	When "1" the internal power on sequence is complete.
6	TRG_EDGE	r/w	When "1" the positive edge is used.
7	OVERCUR_EN	r/w	Enabled / disables the overcurrent protection.
8-9	REG_MODE	r/w	Regulator mode: 0 : manual 1 : semi-automatic 2 : not used 3 : not used
10	reserved	ro	reserved
11	ENABLE_LOCK	ro	Indicates, that the Enable pin must be set to "0" in order to continue normal operation.
12	reserved	ro	reserved
13	reserved	ro	reserved
14-15	TRG_MODE	rw	Trigger mode: 0: internal 1: external 2: external controlled 3: software controlled
16	ENABLED	ro	Indicates that the driver is enabled.

Bit	Name	Read/Write	Meaning
17	reserved	ro	reserved
18	ISOLL_EXT	rw	When “1” the analog current setpoint values will be used.
19	EXEC_SW_PULSE	rw	When “1”, the driver will execute a pulse (in trigger mode 3).
20	EXECUTING_PULSES	ro	Indicates that the driver is currently executing a software trigger.
21	ABORT_EXEC_PULSES	rw	When “1”, the driver will abort the current software trigger.
22	reserved	ro	reserved
23	reserved	ro	reserved
24	FAN_AUTO	rw	When “1” the speed of the cooling fan is regulated automatically.
25-31	reserved	ro	reserved

Description of the ERROR Register

The following list contains a description of the individual bits of the ERROR register. A “1” as a bit leads to a deactivation of the output current.

The ERROR bits are cleared by disabling of the ENABLE pin.

Bit	Name	Read/Write	Meaning
0	CRC_DEVDRV_FAIL	ro	A CRC error was detected in the PLB driver. The driver cannot be used. This does not affect the device but the PLB.
1	CRC_DEFAULT_FAIL	ro	A CRC error was detected in the default values. A re-save of the values should correct this.
2	CRC_CONFIG_FAIL	ro	A CRC error was detected in the internal configuration values. Please contact your distributor.
3	reserved	ro	
4	CRC_FFWDICAL_FAIL_1	ro	A CRC error was detected in the internal calibration values. Please contact your distributor.
5	CRC_FFWDICAL_FAIL_2	ro	A CRC error was detected in the internal calibration values. Please contact your distributor.
6	reserved	ro	
7	reserved	ro	
8	CRC_VCAPCAL_FAIL	ro	A CRC error was detected in the internal calibration values. Please contact your distributor.
9	OCUR_DETECTED	ro	The overcurrent protection has disabled the output.
10	TEMP_OVERSTEPPE D	ro	The internal temperature was beyond safe operating limits.
11	TEMP_WARNING	ro	The internal temperature is 5 °C before shutdown.
12	TEMP_HYSTERESE	ro	Device is cooling down. Temperature needs to drop below (maximum – 10 °C)

Bit	Name	Read/Write	Meaning
13	VOLTAGE_5V_FAIL	ro	Internal supply voltage error.
14	VOLTAGE_12V_FAIL	ro	Internal supply voltage error.
15	VOLTAGE_TOO_LOW	ro	The supply voltage is too low.
16	VOLTAGE_TOO_HIGH	ro	The supply voltage is too high.
17	FAILED_TO_LOAD_DEFAULT	ro	The loading of the default failed. Normally this is because of a pending CRC error.
18	I2C_EEPROM_FAIL	ro	Internal EEPROM error. Please contact your distributor.
19	I2C_DAC_1_FAIL	ro	Internal DAC error. Please contact your distributor.
20	I2C_DAC_2_FAIL	ro	Internal DAC error. Please contact your distributor.
21	I2C_DAC_3_FAIL	ro	Internal DAC error. Please contact your distributor.
22	ENABLE_POWERON	ro	ENABLE and / or MASTER_ENABLE pin was high during power on.
23	UVLO	ro	Indicates that the supply voltage has dropped during operation.
24	PMAX_ERR	ro	Indicates that the maximum power dissipation was overstepped.
25	MAX_REPRATE	ro	Indicates that the maximum repetition rate was overstepped or a trigger occurred while a trigger sequence was running.
26	reserved	ro	reserved
27	TEMP_SENSOR_1_FAULT	ro	Indicates that the on board temperature sensor is faulty.
28	TEMP_SENSOR_2_FAULT	ro	Indicates that the on board temperature sensor is faulty.
29	TEMP_SENSOR_3_FAULT	ro	Indicates that the on board temperature sensor is faulty.
30	TEMP_SENSOR_4_FAULT	ro	Indicates that the on board temperature sensor is faulty.
31	TEMP_SENSOR_5_FAULT	ro	Indicates that the on board temperature sensor is faulty.
32	TEMP_SENSOR_6_FAULT	ro	Indicates that the on board temperature sensor is faulty.
33	FAN_1_SPEED_ERR	ro	Indicates that the speed of fan 1 is too low.
34	FAN_2_SPEED_ERR	ro	Indicates that the speed of fan 2 is too low.
35-63	reserved	ro	reserved